

THIS DRAWING IS UNPUBLISHED. RELEASED FOR PUBLICATION, 19 .
 © COPYRIGHT 19 BY AMP INCORPORATED. ALL INTERNATIONAL RIGHTS RESERVED.

LOC	DIST	P	F	ZONE	LTR	DESCRIPTION	DATE	APPD
G	14				C	REV, RDRW, & SM PKG PER 0720-0040-93	3-17-93	AMP DAP

METRIC
 DIMENSIONS LISTED IN mm [INCHES]

AMP WIRE RANGE	E13288 Listed
12-10 AWG SOLID OR STRANDED	12-10 AWG STRANDED
LR7189 Certified	MILITARY P/N AND CLASS
12-10 AWG SOLID OR STRANDED	MS20659-165 CLASS 2 P/N 35476 & 2-35476-1 ONLY

1 STAMP AMP 12-10* APPROX AS SHOWN

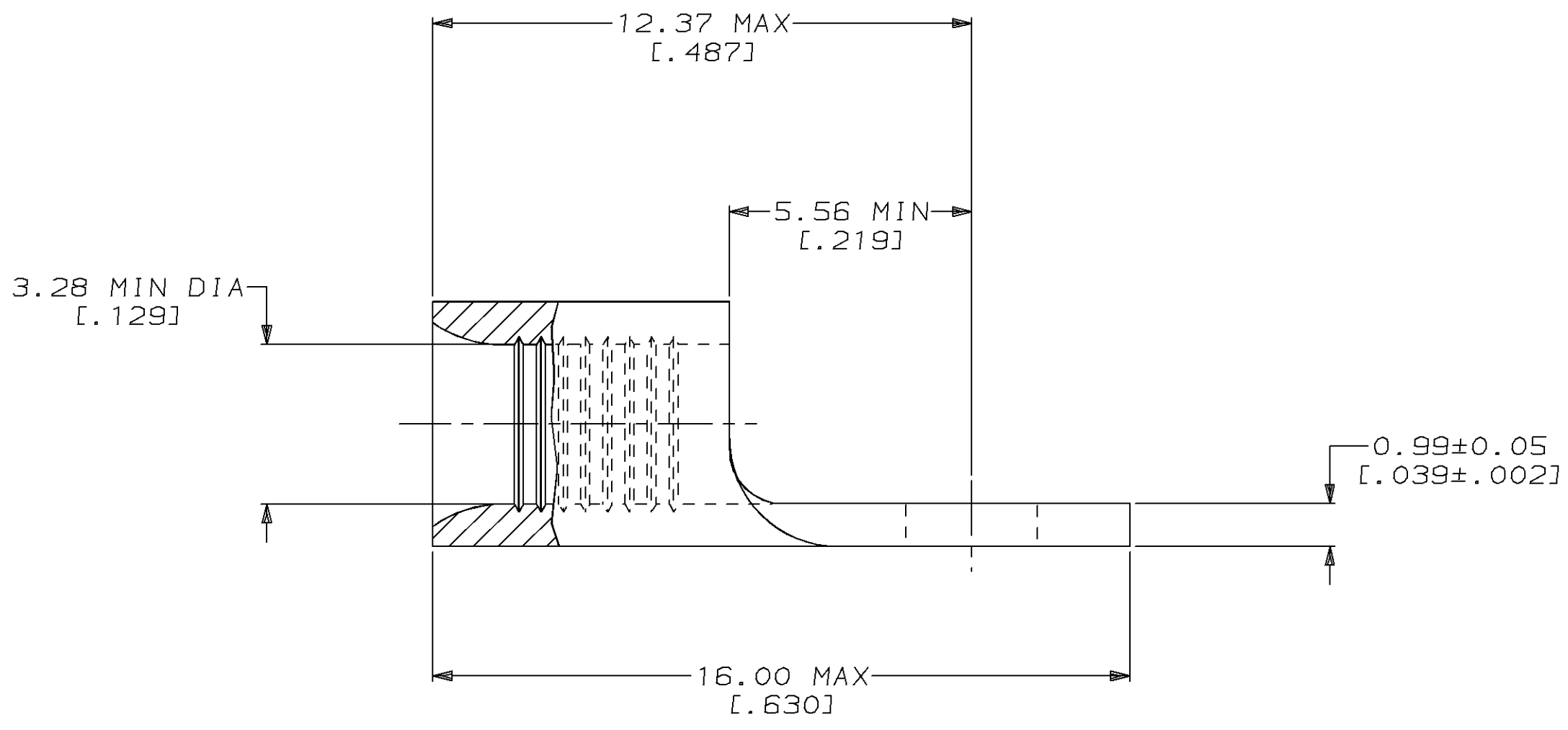
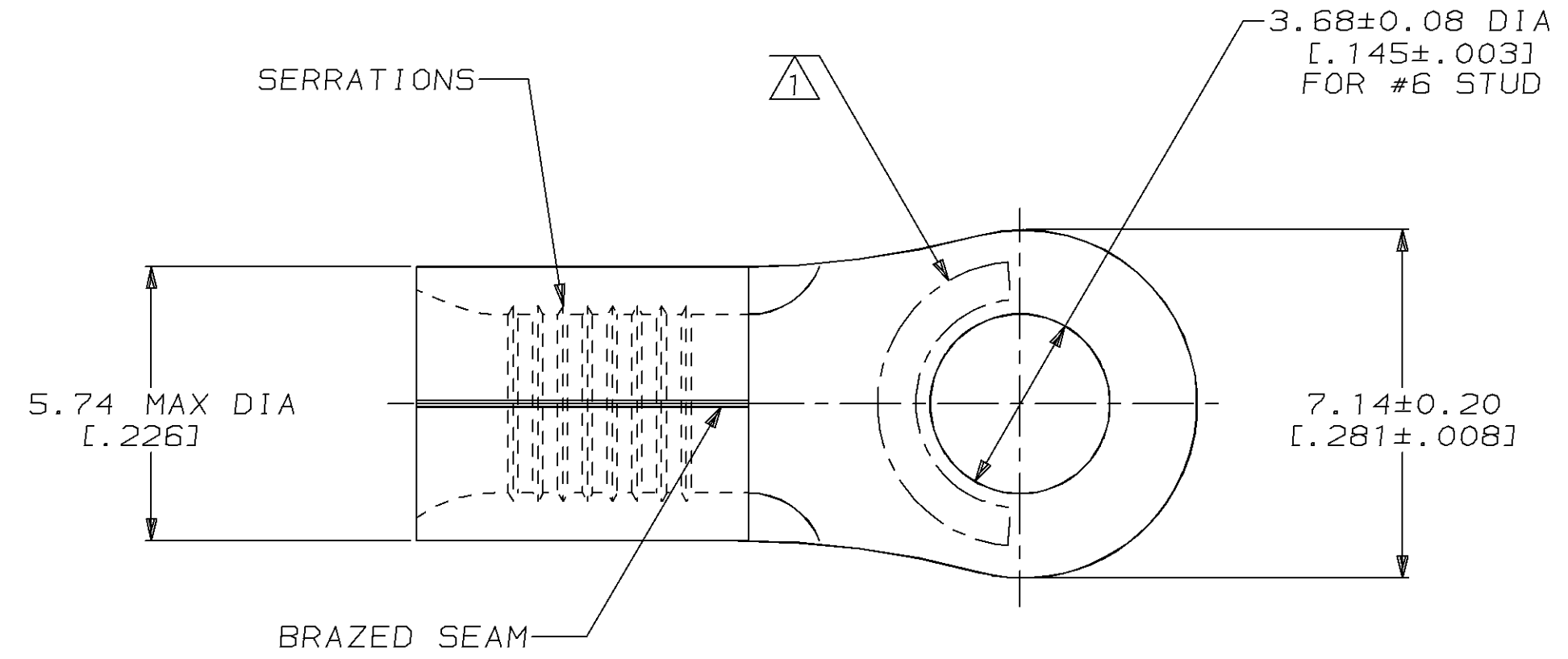

50	LOOSE PIECE, BOX	8-35476-2
2000	ON TAPE	2-35476-1
---	LOOSE PIECE	35476
QUANTITY	PACKAGING TYPE	PART NO

AMP INCORPORATED
CUSTOMER SERVICE SYSTEMS

FOR ADDITIONAL PRODUCT INFORMATION OR COPIES OF DRAWINGS AND TECHNICAL DOCUMENTS
 PRODUCT INFORMATION CENTER
 1-800-522-6752

FOR APPLICATION TOOLING INFORMATION
 TOOLING ASSISTANCE CENTER
 1-800-722-1111

FOR ORDER ENTRY
 1-800-526-5142

MAX RECOMMENDED OPERATING TEMPERATURE:
 170°C MAX

VOLTAGE RATING:
 NOT APPLICABLE

WIRE CROSS SECTIONAL AREA RANGE:
 2.62-6.64mm² [5,180-13,100] CIR MILS
 SOLID OR STRANDED

THIS DRAWING IS A CONTROLLED DOCUMENT FOR AMP INCORPORATED. IT IS SUBJECT TO CHANGE AND THE CONTROLLING ENGINEERING ORGANIZATION SHOULD BE CONTACTED FOR THE LATEST REVISION.

DO NOT SCALE PRINT. UNLESS SPECIFIED DIMENSIONS IN mm [INCHES] - TOLERANCES ON :
 2 PLC DEC ± -
 3 PLC DEC ± -
 ANGLES ± -

MATERIAL
 COPPER PER ASTM B-152 ANNEALED

FINISH
 TIN PLATE 0.00254 [0.000100] MIN THK PER MIL-T-10727

DR 3-17-93 TA BRINKMAN
 CHK 3-17-93 DA PATTERSON
 APPD 3-17-93 DE MILLER
 APPD 3-17-93 JL MECKLEY
 PRODUCT SPEC -
 APPLICATION SPEC -
 WEIGHT -

AMP AMP Incorporated
 Harrisburg, PA 17105-3608

NAME
TERMINAL, RING TONGUE, SOLISTRAND™

SIZE [C] CAGE CODE 00779 DRAWING NO G-35476
 SCALE 8:1 SHEET 1 OF 1